

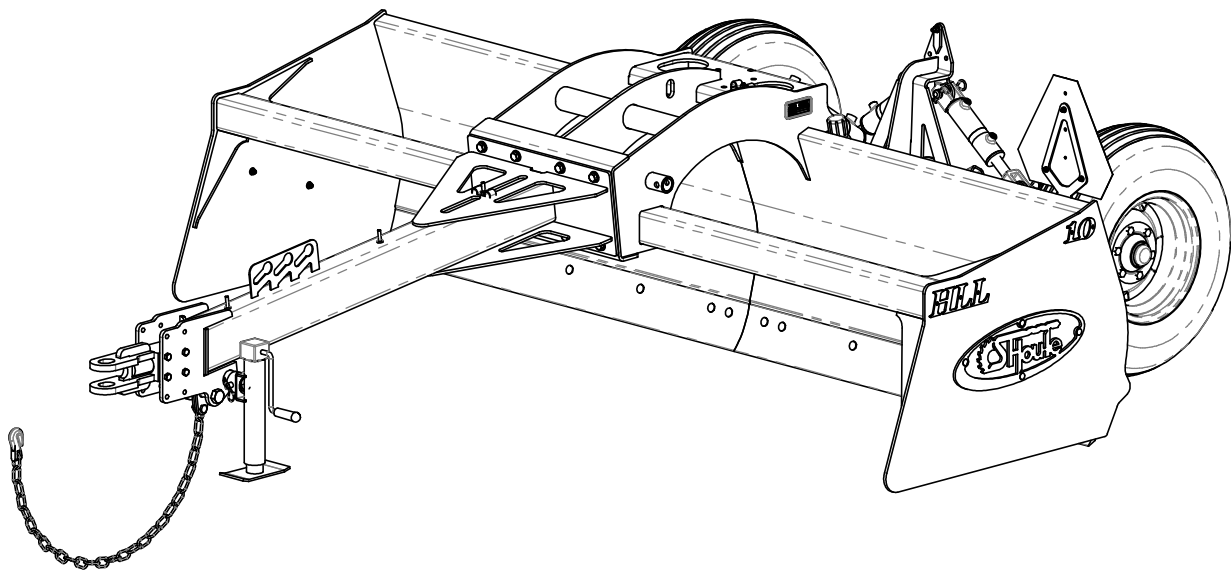

OWNER'S MANUAL



CAT # N01-60002

LAND LEVELER CAT.01 (HLL) 8', 10', 12'
N0108-00003, N0110-00003, N0112-00003



Introduction.....	3
Safety	4
Dimensions	9
Maintenance	10
Mounting instruction	11
Parts	13
Land leveler cat. 01 (HLL) 8', 10', 12'	13
Land leveler frame kit cat. 01 (HLL) 8', 10', 12'	15
Scarifier teeth assembly HLL 8',10', 12'	17
Premium level indicator kit (HLL)	18
Land leveler hyd. hoses kit	19
Land leveler hyd. hoses kit (swing arm)	20
Land leveler cat. 01 hydraulic kit (HLL)	21
Land leveler cat. 01 hyd. kit (HLL) (W/O tilt)	22
Laser post kit (HLL)	23
GPS post kit (HLL)	24
Option female attachment	25
Warranty	26
Product registration	27



Congratulations on your purchase of your new **Fabrication S. Houle inc**, equipment!

This equipment will advantageously complement your agricultural machinery. It has been designed and built specifically for an agricultural market that is always in need of more efficient, better performing equipment.

This **Owner's Manual** is your principal reference in regards to your new equipment. To ensure your equipment delivers many years of quality use, it is important that you follow the use and maintenance guidelines set out in this manual. We urge you and those who will be using and/or performing maintenance on this equipment to ensure that **you have read and understood the contents of this manual prior to first use.**

Please keep this **Owner's Manual** within reach so that you may quickly consult it, as often as necessary. In case of ownership transfer, please ensure that you also remit this manual to the new owner or user.

Should you have any questions, or to obtain more information or additional copies of this manual, please contact us at:

Fabrication S. Houle Inc.

300 Industrial Boulevard
St-Germain-de-Grantham, Qc. Canada J0C 1K0
Tel.: (819) 395-4380 Fax: (819) 395-5516
Toll Free: 1-888-404-4380
Email: info@shoule.com
Web: www.shoule.com

Locate this symbol – it could save your life

This symbol is the standard safety symbol. You will find it on most of the decals on your equipment. It is also used throughout this manual.

This symbol is used mainly to draw your attention and to warn you of possible dangers and/or potential injuries.



It is vital that you read and understand completely the following instructions and safety rules prior to using your equipment.



The safety symbol accompanied by the word “DANGER” indicates an immediate danger capable of causing serious injury or death.



The safety symbol accompanied by the word “WARNING” indicates a potential danger capable of causing serious injury or death.



The safety symbol accompanied by the word “CAUTION” indicates a potential danger capable of causing injury.

Being well informed is your best protection against accidents. It is therefore important that you give particular attention to the safety guidelines presented in this manual.

Think SAFETY! Work SAFELY!



As the owner of this equipment, you are responsible for the safety of its users and those who are responsible for its maintenance. You and any other person using or performing maintenance on this equipment must be familiar with its operation and maintenance, as well as the safety measures contained in this manual. Having safe working practices guarantees a safer work environment.

The owner of this equipment must inform any user of all instructions related to proper operation and use of this equipment, prior to first use.

The user must read, understand and respect all operating and safety instructions contained in this manual. A user who is unaware or ignores the operating and safety instructions contained herein is not qualified to operate this equipment, and exposes him/herself and bystanders to possible serious injury and or death.

Do not in any way modify this equipment. Unauthorized modifications could impair the proper functioning and/or safety of this equipment and possibly affect its useful life as well.

General Safety Measures

1. Read and understand all operating and safety instructions and guidelines contained in this manual prior to using, maintaining or adjusting the equipment.
2. Ensure all safety guards and shields are properly installed prior to using the equipment.
3. Always have a first aid kit within reach, and know how to use it.
4. Always have a fire extinguisher within reach, and know how to use it.
5. Wear appropriate safety gear, such as: hard hat, safety boots, safety goggles, gloves, ear plugs, etc.
6. Clear the area of people, especially children, prior to engaging the equipment.

Operating Safety

In addition to reading and fully understanding this manual,



you should:

1. Lower the equipment, stop the tractor's engine, set controls to neutral, engage the emergency brake, remove the tractor's ignition key and wait for all moving parts to come to a full stop prior to detaching or servicing the equipment.
2. Keep hands, feet, hair and all clothing away from all moving parts and/or rotating parts.
3. Do not allow bystanders on the equipment or the tractor.
4. Do not remove protective guards or shields. Ensure they are in place and properly attached.
5. Clear the area of all people, especially small children, prior to engaging the equipment and/or the tractor.
6. Be extremely cautious while servicing or while near high pressure hydraulic systems. Ensure all components are fully sealed and in good working order prior to operating the equipment.
7. Ensure all reflectors, lights and the safety triangle are clean prior to transportation on public roads. Check with local authorities to ensure you are compliant with all lighting requirements.

Maintenance Safety

In addition to reading and fully understanding this manual, you should:

1. Lower the equipment, stop the tractor's engine, set controls to neutral, engage the emergency brake, remove the tractor's ignition key and wait for all moving parts to come to a full stop prior to detaching or servicing the equipment.
2. Keep hands, feet, hair and all clothing away from all moving parts.
3. Clear the area of all people, especially small children, prior to engaging the equipment and/or the tractor.
4. Place safety stands or blocks underneath the frame prior to working underneath the equipment.

5. Be extremely cautious while servicing or while near high pressure hydraulic systems. Ensure all components are fully sealed and in good working order prior to operating the equipment. Wear appropriate safety gear to protect your eyes and hands. Use a piece of wood or cardboard as a shield when examining a hose or fitting for a leak.
6. Always relieve pressure prior to disconnecting or servicing hydraulics.
7. Always use original parts when any need replacing.
8. Do not in any way modify this equipment, its components or its intended use. Fabrication S.Houle inc. will not be held responsible should breakage or injury occur as a result of using any non-approved parts or accessories.
9. Do not operate equipment that is defective or that has parts missing.
10. Inspect nuts and bolts regularly and ensure they are tightly secured.

Hydraulic System Safety

In addition to reading and fully understanding this manual, you should:

1. Always set the hydraulic controls to neutral prior to disassembling the hydraulic system.
2. Be extremely cautious while servicing or while near high pressure hydraulic systems. Ensure all components are fully sealed and in good working order prior to operating the equipment. Wear appropriate safety gear to protect your eyes and hands. Use a piece of wood or cardboard as a shield when examining a hose or fitting for a leak.

Transportation Safety

In addition to reading and fully understanding this manual, you should:

1. Check with local authorities to ensure you are compliant with all machinery transportation safety requirements.



Storage Safety

1. Store the equipment in an area well away from human activity.
2. Store the equipment in the lowered position.
3. Do not allow children to play near the stored equipment.

Greasing

Locate the greasing decals (see illustration on right)

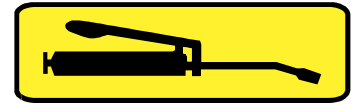

1. Use a manual grease gun
2. Clean the couplers and fittings with a clean cloth prior to lubricating
3. Replace and repair damaged or broken couplers
4. If couplers are difficult to lubricate, remove them so as to be able to clean them thoroughly, and replace them if necessary. Also clean the lubricant passageway
5. Inject lubricant until the excess is expelled through the bearing or bushing areas

Types of Lubricants

Grease

Use an SAE multi-purpose high temperature grease with extreme pressure (EP) performance†. A lithium-based SAE multi-purpose grease is also acceptable.



LAND LEVELER CAT.01 (HLL) 8', 10', 12'
N0108-00003, N0110-00003, N0112-00003

Dimensions

(10 ft model show)

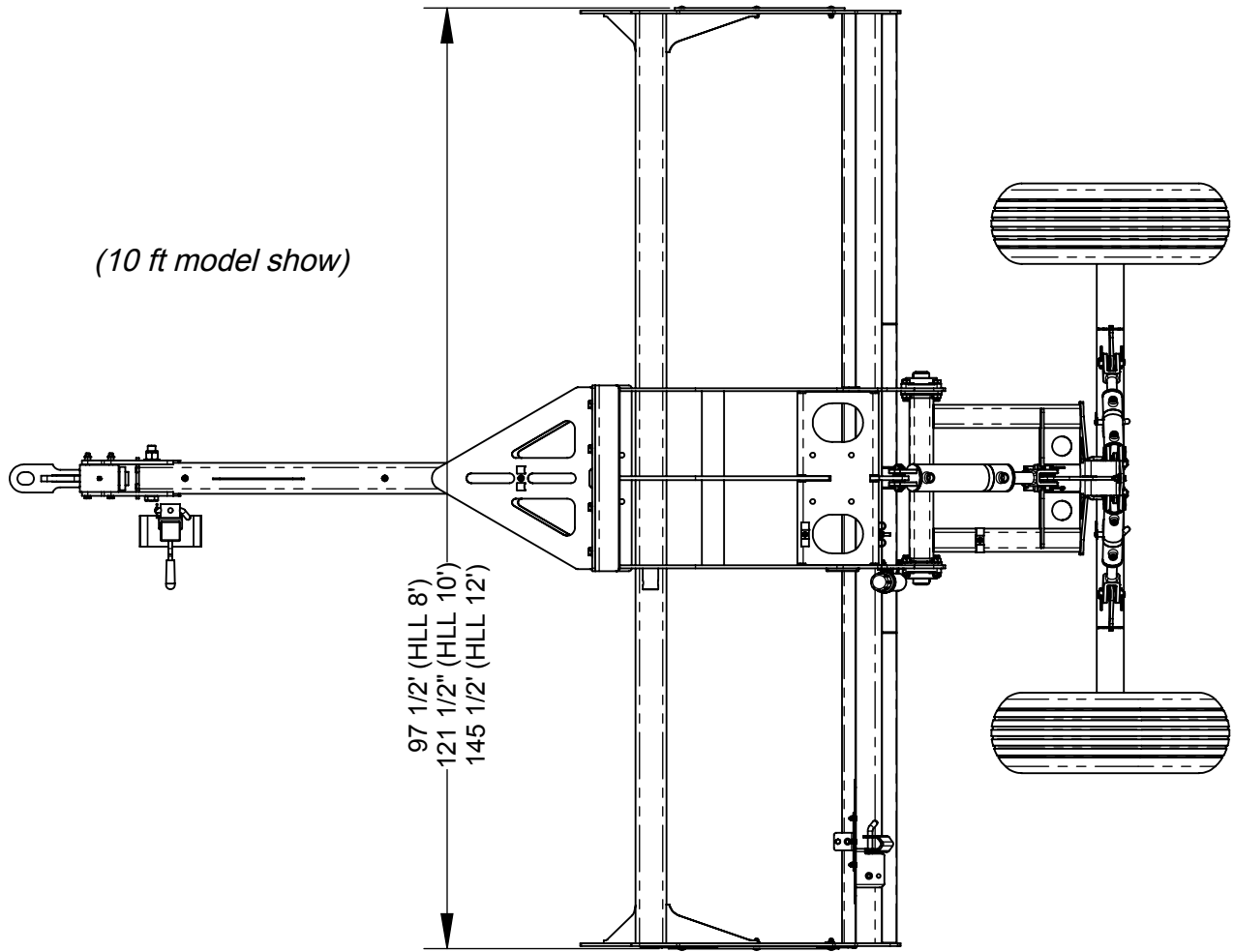

1850 lbs (HLL 8')
Weight: 1875 lbs (HLL 10')
1985 lbs (HLL 12')

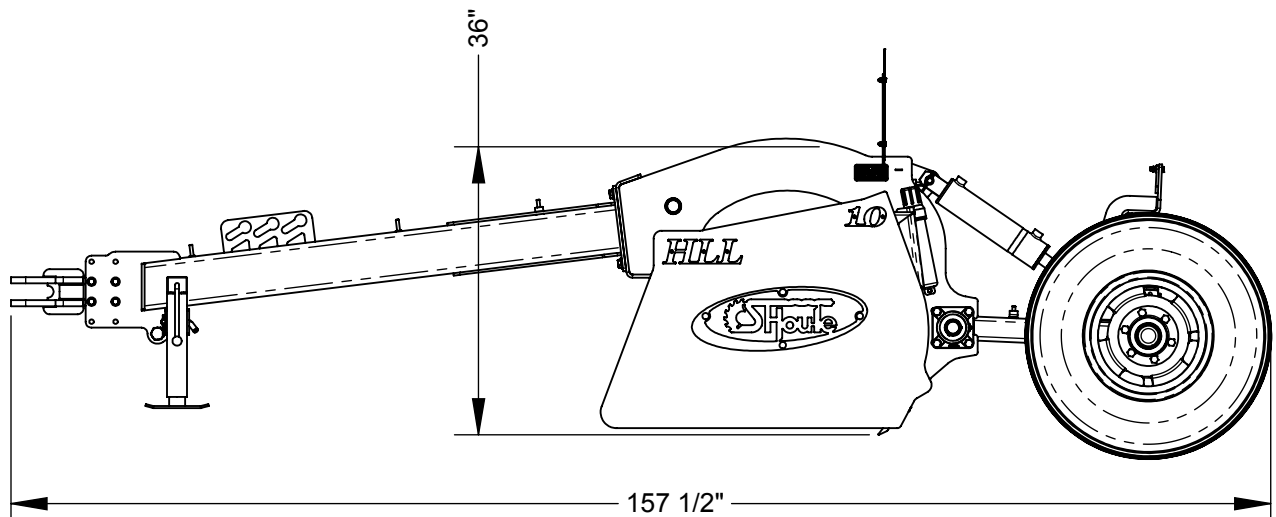



STEP 1

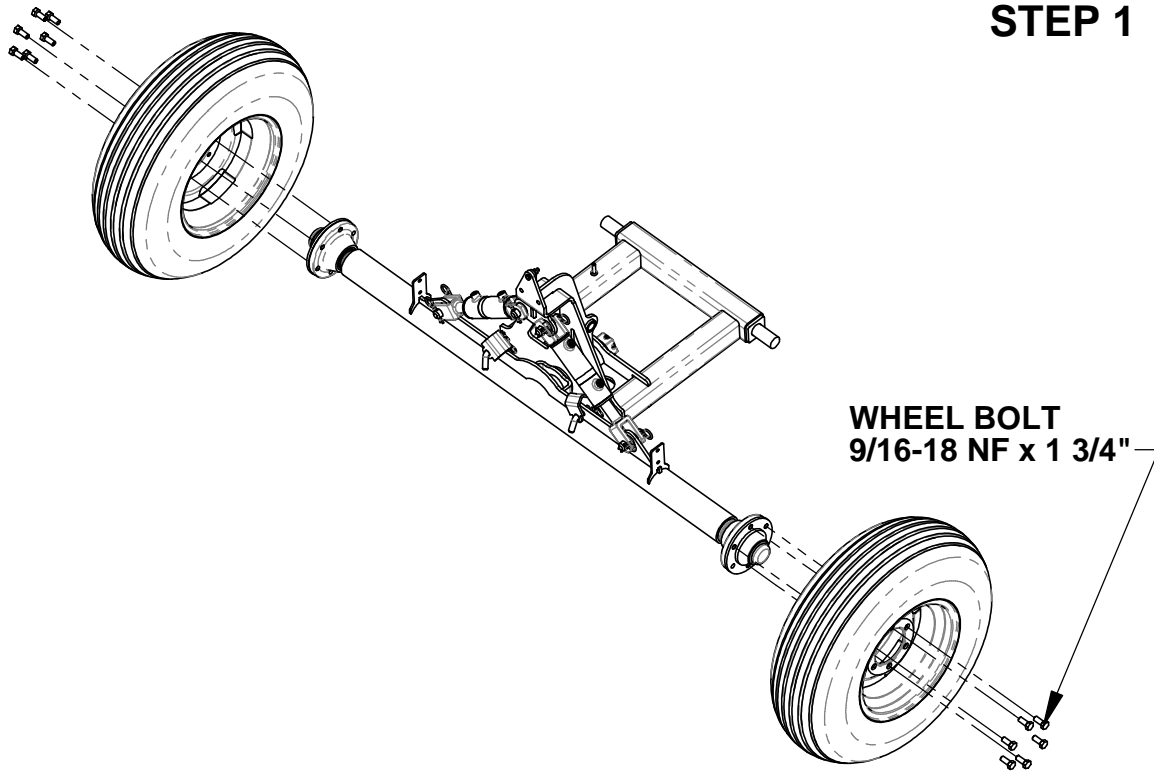

STEP 2

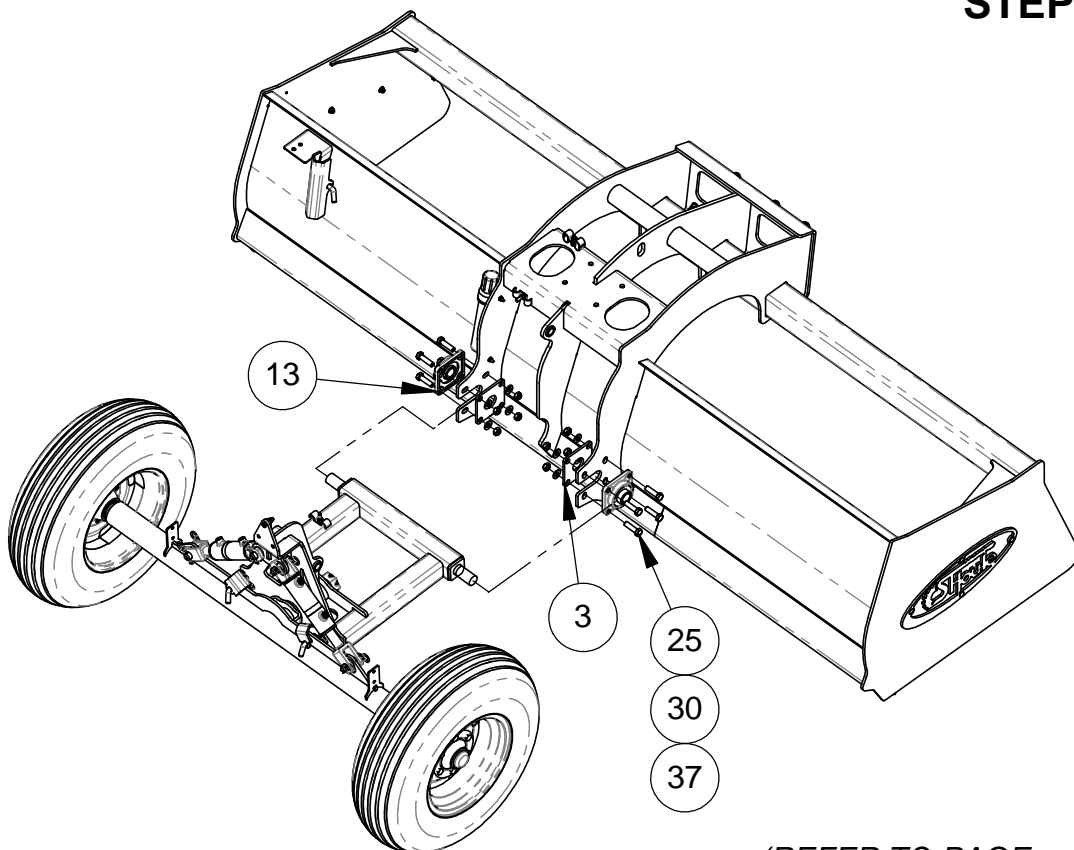

(REFER TO PAGE ... FOR
ITEMS DESCRIPTION)



DETAIL A
SCALE 1:14

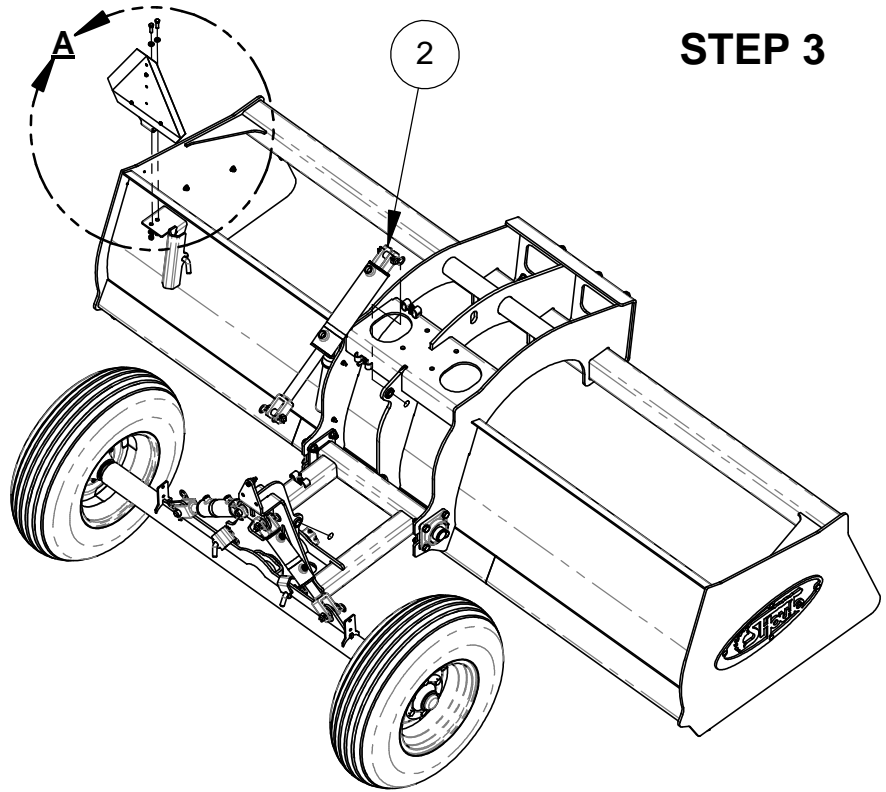
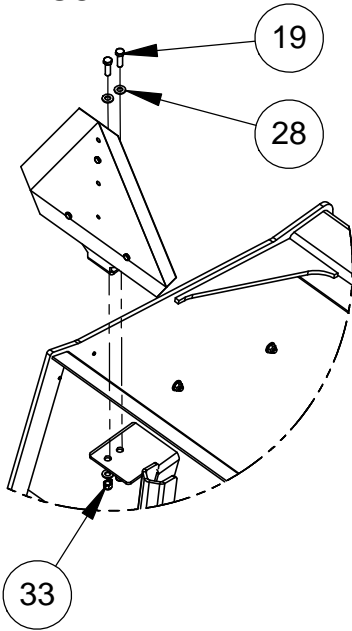

STEP 3

STEP 4

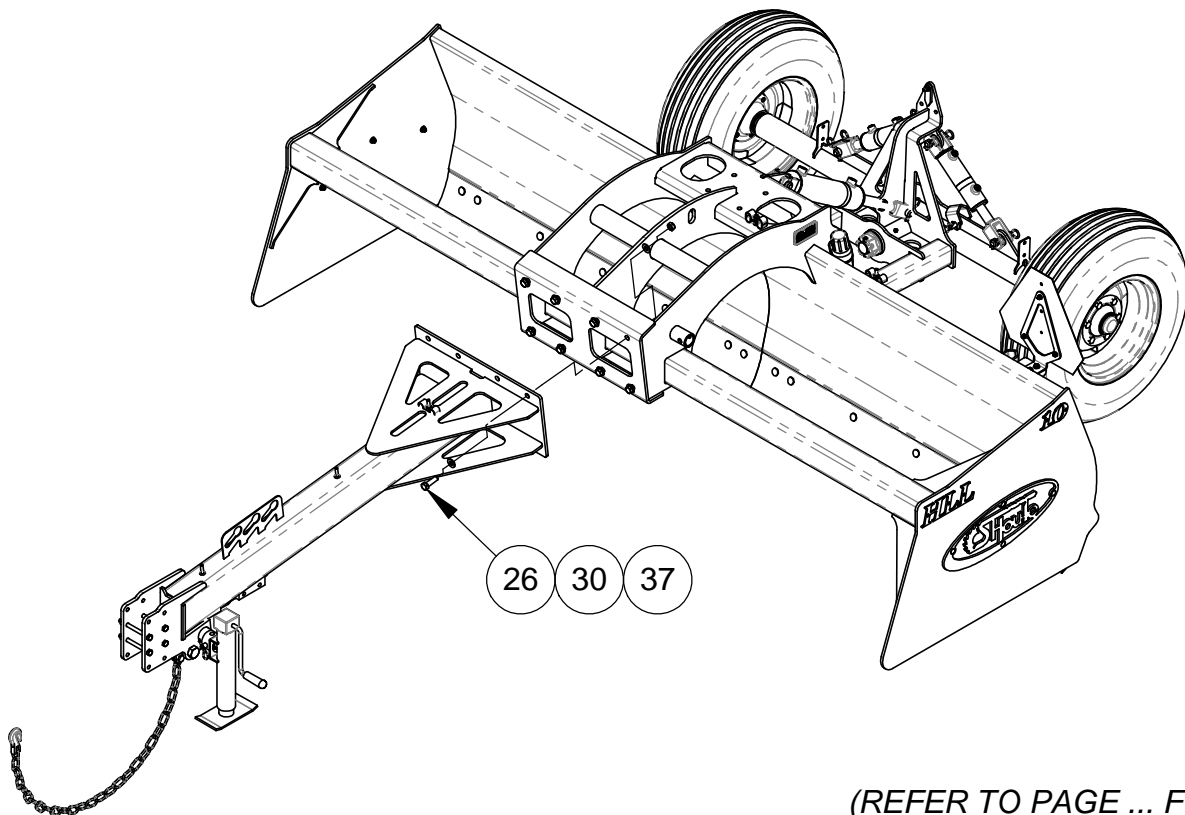

(REFER TO PAGE ... FOR
ITEMS DESCRIPTION)



LAND LEVELER CAT.01 (HLL) 8', 10', 12'
N0108-00003, N0110-00003, N0112-00003

Parts

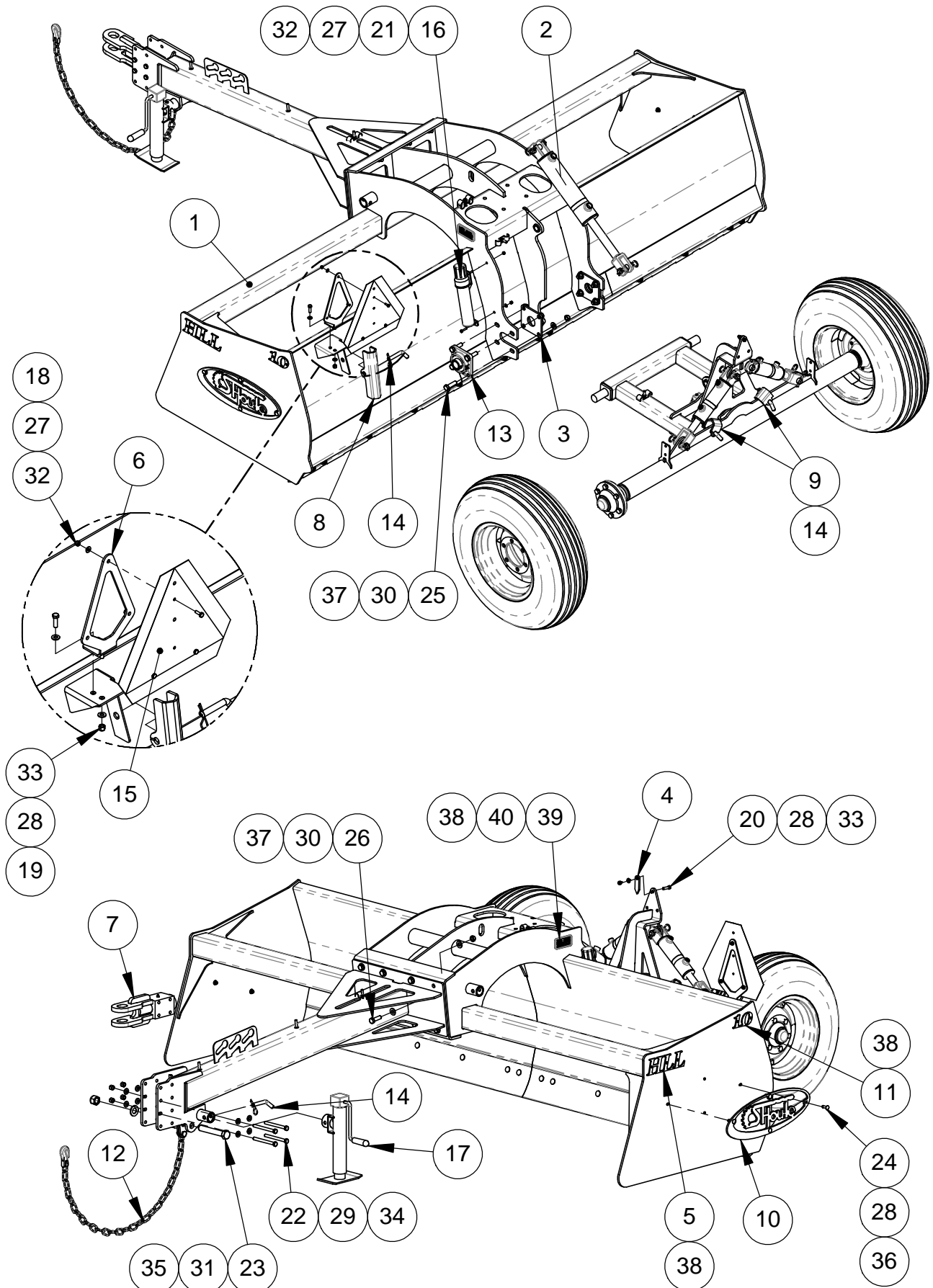



LAND LEVELER CAT.01 (HLL) 8', 10', 12'
N0108-00003, N0110-00003, N0112-00003

Parts

ITEM	PART NUMBER			DESCRIPTION	QTY
	<i>HLL 8'</i>	<i>HLL 10'</i>	<i>HLL 12'</i>		
1	N0108-05E03	N0110-05E03	N0112-05E03	LAND LEVELER FRAME KIT CAT.01 (HLL)	1
2	N01-31E01	N01-31E01	N01-31E01	LAND LEVELER CAT.01 HYDRA. KIT (HLL)	1
3	N-01048	N-01048	N-01048	BEARING SUPPORT 1 1/2"	2
4	N-01049	N-01049	N-01049	LEVEL INDICATOR	1
5	N-59015	N-59015	N-59015	HLL LOGO	1
6	UN-36001	UN-36001	UN-36001	SMV HOLDER	1
7	UN-20072	UN-20072	UN-20072	FEMALE ATTACHMENT PIN 1 1/2"	1
8	UN-43004-04	UN-43004-04	UN-43004-04	CYL LOCKING DEVICE (10" X 1 1/2")	1
9	UN-43004-07	UN-43004-07	UN-43004-07	CYL LOCKING DEVICE (2 1/2" X 1 1/2")	2
10	UN-59001-4	UN-59001-4	UN-59001-4	S HOULE LOGO 8"	2
11	UN-59005	UN-59005-2	UN-59005-3	LOGO (8) (10) (12)	1
12	07037-5	07037-5	07037-5	CHAIN SAFETY 1/4" x 46" Lg - 11,000 lb	1
13	34006-2	34006-2	34006-2	FLANGE BEARING 1 1/2" UCF208-24	2
14	35011	35011	35011	BENT PULL PIN 5/8" X 3"	4
15	36002	36002	36002	SLOW MOVING VEHICLE SIGN (SMV)	1
16	36001-2	36001-2	36001-2	MANUAL HOLDER 2"	1
17	43004	43004	43004	JACK 3000 LBS	1
18	45AA004200012	45AA004200012	45AA004200012	HEX BOLT 1/4-20NC x 3/4" GR5	3
19	45AA006160104	45AA006160104	45AA006160104	HEX BOLT 3/8-16NC x 1 1/4" GR5	2
20	45AA006160108	45AA006160108	45AA006160108	HEX BOLT 3/8-16NC x 1 1/2" GR5	1
21	45AA004200104	45AA004200104	45AA004200104	HEX BOLT 1/4-20NC x 1 1/4" GR5	2
22	45AA008130508	45AA008130508	45AA008130508	HEX BOLT 1/2-13NC x 5 1/2" GR5	4
23	45AA100080608	45AA100080608	45AA100080608	HEX BOLT 1-8NC X 6 1/2" GR5	1
24	45CC006160104	45CC006160104	45CC006160104	CARRIAGE BOLT 3/8"-16NC X 1 1/4" GR5	8
25	45AA010110204	45AA010110204	45AA010110204	HEX BOLT 5/8-11NC x 2 1/4" GR5	8
26	45AA010110200	45AA010110200	45AA010110200	HEX BOLT 5/8-11NC X 2" GR5	8
27	46AB004	46AB004	46AB004	HARDENED FLAT WASHER 1/4"	5
28	46AB006	46AB006	46AB006	HARDENED FLAT WASHER 3/8"	13
29	46AB008	46AB008	46AB008	HARDENED FLAT WASHER 1/2"	8
30	46AB010	46AB010	46AB010	HARDENED FLAT WASHER 5/8	24
31	46AB100	46AB100	46AB100	HARDENED FLAT WASHER 1"	1
32	47AB00420	47AB00420	47AB00420	NYLON LOCK NUT 1/4-20 NC	5
33	47AB00616	47AB00616	47AB00616	NYLON LOCK NUT 3/8"-16NC	3
34	47AB00813	47AB00813	47AB00813	NYLON LOCK NUT 1/2-13 NC	4
35	47AB10008	47AB10008	47AB10008	NYLON LOCK NUT 1"-8NC	1
36	47AC00616	47AC00616	47AC00616	STOVER LOCK NUT 3/8-16NC	8
37	47AC01011	47AC01011	47AC01011	STOVER LOCK NUT 5/8-11NC	16



LAND LEVELER FRAME KIT CAT.01 (HLL) 8', 10', 12'
N0108-05E03, N0110-05E03, N0112-05E03

Parts

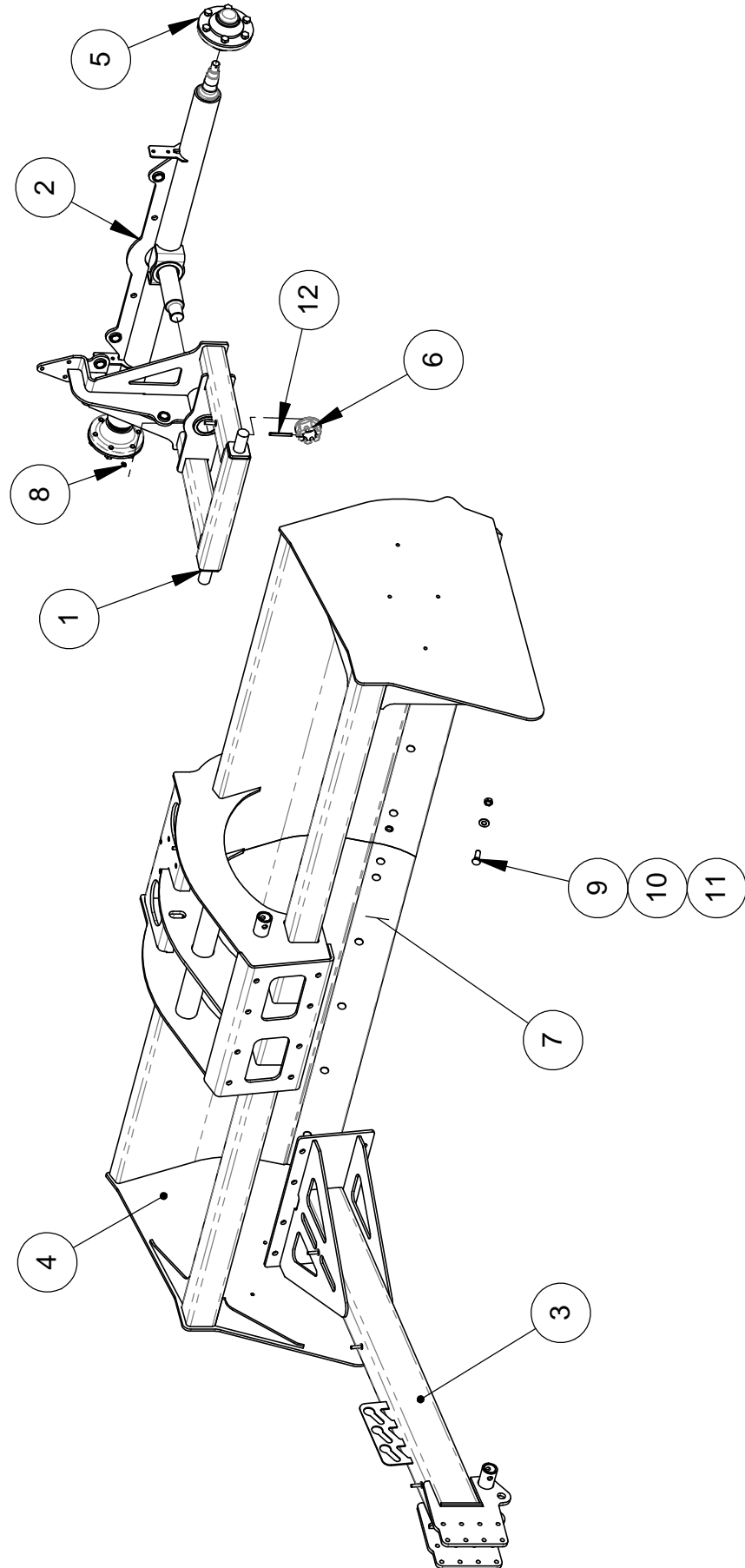



LAND LEVELER FRAME KIT CAT.01 (HLL) 8', 10', 12'
N0108-05E03, N0110-05E03, N0112-05E03

Parts

ITEM	PART NUMBER			DESCRIPTION	QTY
	<i>HLL 8'</i>	<i>HLL 10'</i>	<i>HLL 12'</i>		
1	N-01166	N-01166	N-01166	SWING ARM CAT. 01 (HLL)	1
2	N-01167	N-01167	N-01167	SWIVEL AXLE HLL	1
3	N-05274	N-05274	N-05274	DRAW BAR CAT.01 (HLL)	1
4	N-05311	N-05275	N-05290	LAND LEVELER FRAME CAT.01 10 ft (HLL)	1
5	01002	01002	01002	5000 LBS HUB	2
6	01008-5	01008-5	01008-5	CASTEL NUT 1 3/4-12 UN	1
7	* 21012-3	21012	21012-2	ROUND CUTTING EDGE 5/8" X 6" X 5' (5/8")	2
8	35012	35012	35012	STRAIGHT GREASE FITTING 1/8 NPT	1
9	45CA010110200	45CA010110200	45CA010110200	SCRAPER BOLT DOME HEAD 5/8"-11NC X 2" GR5	14
10	46AB010	46AB010	46AB010	HARDENED FLAT WASHER 5/8	14
11	47AC01011	47AC01011	47AC01011	STOVER LOCK NUT 5/8-11NC	14
12	49AA060300	49AA060300	49AA060300	SPRING PIN 3/8" X 3"	1

* Only 1 blade



SCARIFIER TEETH ASSEMBLY HLL 8', 10', 12'

N01108-21E02, N0110-21E02, N0112-21E02

Parts

ITEM	PART NUMBER			DESCRIPTION	QTY
	HLL 8'	HLL 10'	HLL 12'		
1	N0108-29E01	N0110-29E01	N0112-29E01	SCARIFIER TEETH HYD. HOSES KIT	1
2	N-05065	N-05065	N-05065	FRAME	2
3	N-05067	N-05067	N-05067	VERTICAL FRAME	2
4	N-21E01	N-21E01	N-21E01	SCARIFIER TOOTH TIGER (ASSEMBLY)	7
5	N-21015	N-21014	N-21016	SCARIFYING FRAME	1
6	UN-25001-8	UN-25001-8	UN-25001-8	PIN 1"X 3 1/2"	4
7	UN-30563	UN-30563	UN-30563	HYD CYLINDER 2 X 8 X CL100	1
8	UN-30564	UN-30564	UN-30564	HYD CYLINDER 2 X 8 X CL100	1
9	35003-8	35003-8	35003-8	U BOLT 5/8-11NC X 4" X 6"	8
10	45AA010110208	45AA010110208	45AA010110208	HEX BOLT 5/8-11NC X 2 1/2" GR5	7
11	45AA006160208	45AA006160208	45AA006160208	HEX BOLT 3/8-16NC x 2 1/2" GR5	7
12	47AC01011	47AC01011	47AC01011	STOVER LOCK NUT 5/8-11NC	7
13	47AB00616	47AB00616	47AB00616	NYLON LOCK NUT 3/8"-16NC	7
14	47AE01011	47AE01011	47AE01011	FLANGE NUT 5/8-11NC	16
15	49AA050200	49AA050200	49AA050200	SPRING PIN 5/16"X2"	8

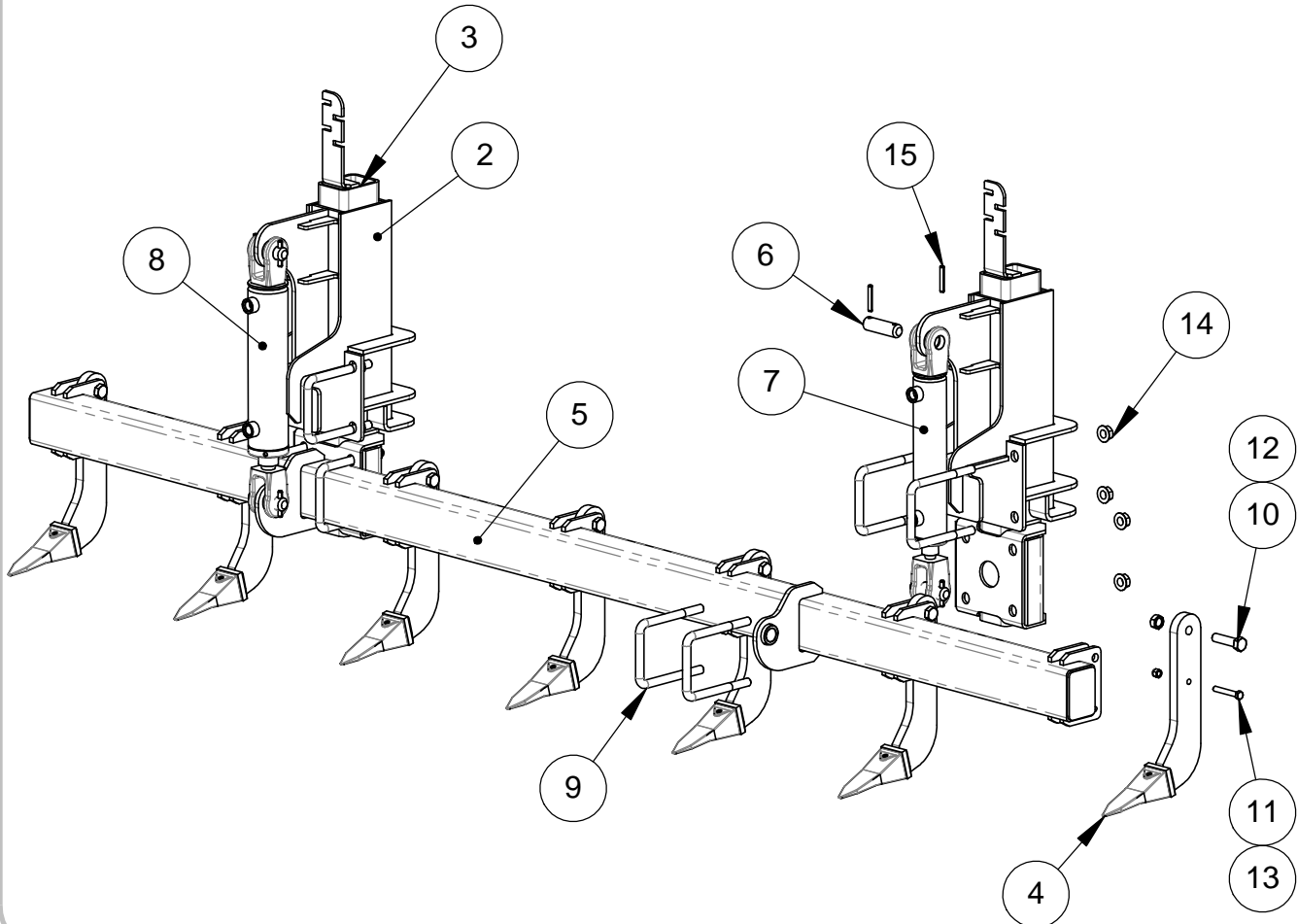



PREMIUM LEVEL INDICATOR KIT (HLL)

N01-01E02 (OPTION)

Parts

ITEM	NO	DESCRIPTION	QTY
1	N-01127	INDICATOR SUPPORT	1
2	N-01128	INDICATOR	1
3	45AE006160104	WHIZ-LOCK BOLT 3/8"-16NC X 1 1/4"	6
4	46AB006	HARDENED FLAT WASHER 3/8"	6
5	47AB00616	NYLON LOCK NUT 3/8"-16NC	6

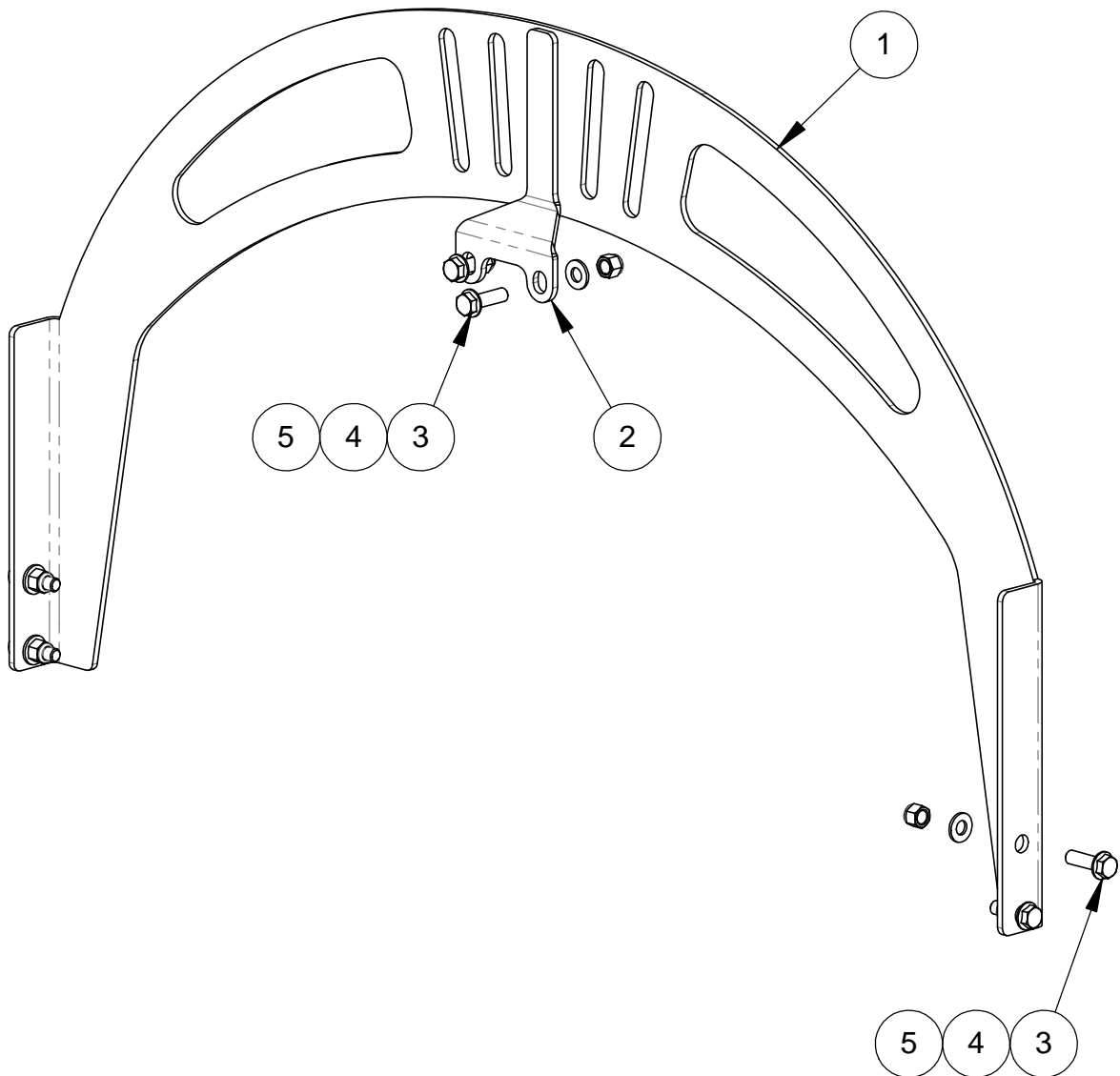



LAND LEVELER HYD. HOSES KIT HLL
N01-29E02 (OPTION)

Parts

ITEM	NO	DESCRIPTION	QTY
1	UN-29001-023	HYD. HOSE 3/8" LP 3/8" JIC(F) x 3/8" JIC(F) X 23"	2
2	UN-29028-170	HYD. HOSE 3/8" LP 3/8" JIC(F) x 1/2" ORB(M) X 170"	1
3	UN-29028-180	HYD. HOSE 3/8" LP 3/8" JIC(F) x 1/2" ORB(M) X 180"	1
4	UN-29028-203	BOYAU HYD. 3/8" LP 3/8" JIC(F) x 1/2" ORB(M) X 203"	2
5	31002-4	ADAP. 3/8" JIC(M) / 3/8" ORB(M) / 3/8" JIC(M)(TEE)	2
6	31013-2	90° HYD FITTING 1/2"ORB(M) / 3/8"JIC(M)	2
7	31013-5	ADAP. 3/8" ORB(M) / 3/8" JIC(M)(90)	2
8	31016-2	QUICK COUPLER MALE 1/2"ORB(F) (S71-15P)	4

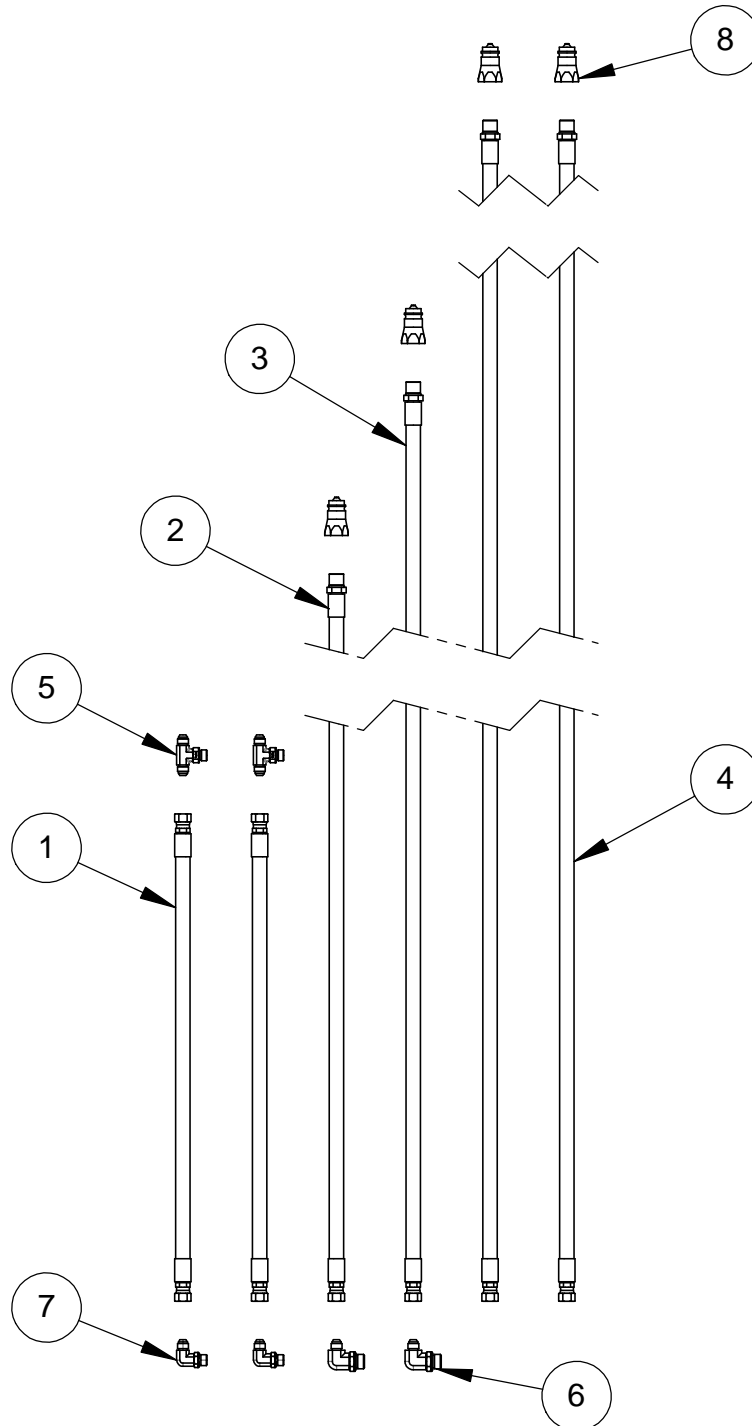



LAND LEVELER HYD. HOSES KIT HLL (SWING ARM)

Parts

N01-29E03 (OPTION)

ITEM	NO	DESCRIPTION	QTY
1	UN-29028-170	HYD. HOSE 3/8" LP 3/8" JIC(F) x 1/2" ORB(M) X 170"	1
2	UN-29028-180	HYD. HOSE 3/8" LP 3/8" JIC(F) x 1/2" ORB(M) X 180"	1
3	31013-2	90° HYD FITTING 1/2"ORB(M) / 3/8"JIC(M)	2
4	31016-2	QUICK COUPLER MALE 1/2"ORB(F) (S71-15P)	2

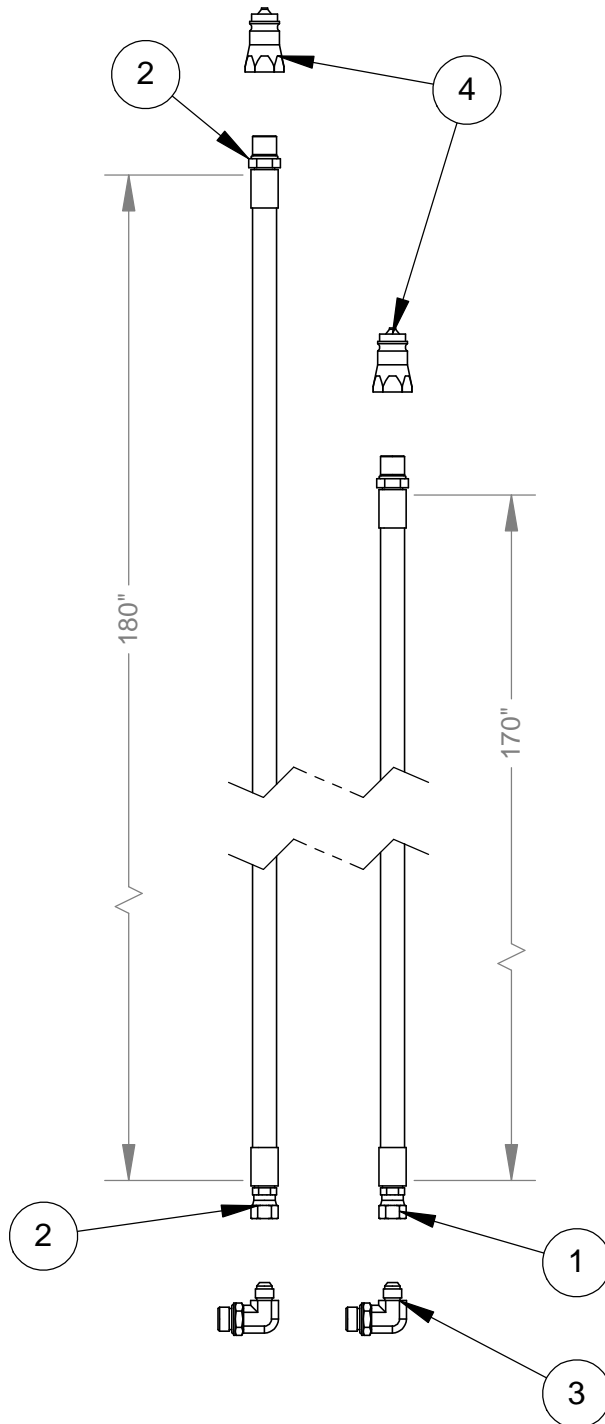



LAND LEVELER CAT.01 HYDRAULIC KIT (HLL) N01-31E01 (OPTION)

Parts

ITEM	NO	DESCRIPTION	QTY
1	N01-29E02	LAND LEVELER HYD. HOSES KIT HLL	1
2	30001	HYD. CYLINDER 2" X 4" (CLEVIS)	2
3	30002-5	HYD. CYLINDER 3" X 10" (CLEVIS)	1
4	31015-2	DOUBLE HOSE CLAMP 3/4"	10
5	47AB00616	NYLON LOCK NUT 3/8"-16NC	6

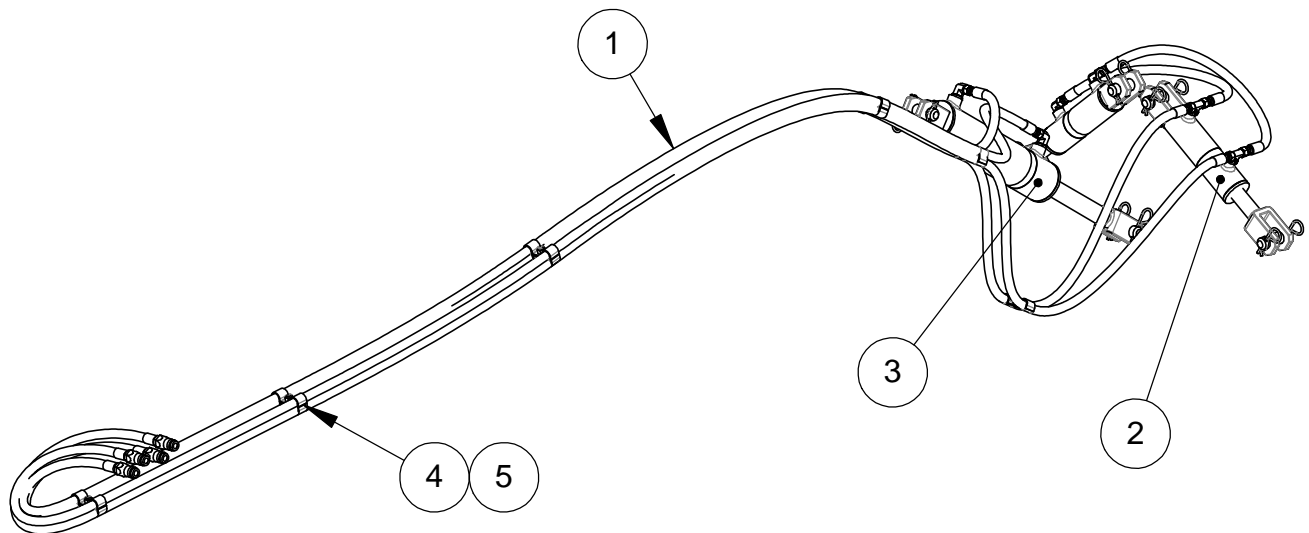



LAND LEVELER CAT.01 HYD. KIT (HLL) (W/O TILT)

Parts

N01-31E02 (OPTION)

ITEM	NO	DESCRIPTION	QTY
1	N01-29E03	LAND LEVELER HYD. HOSES KIT HLL (SWING ARM)	1
2	N-01111	ADJUSTABLE LINK 16 1/4" LG (HLL)	2
3	UN-25001-8	PIN 1" X 3 1/2"	6
4	30002-5	HYD. CYLINDER 3" X 10" (CLEVIS)	1
5	31015-2	DOUBLE HOSE CLAMP 3/4"	5
6	47AB00616	NYLON LOCK NUT 3/8"-16NC	5
7	49AA050200	SPRING PIN 5/16" X 2"	12

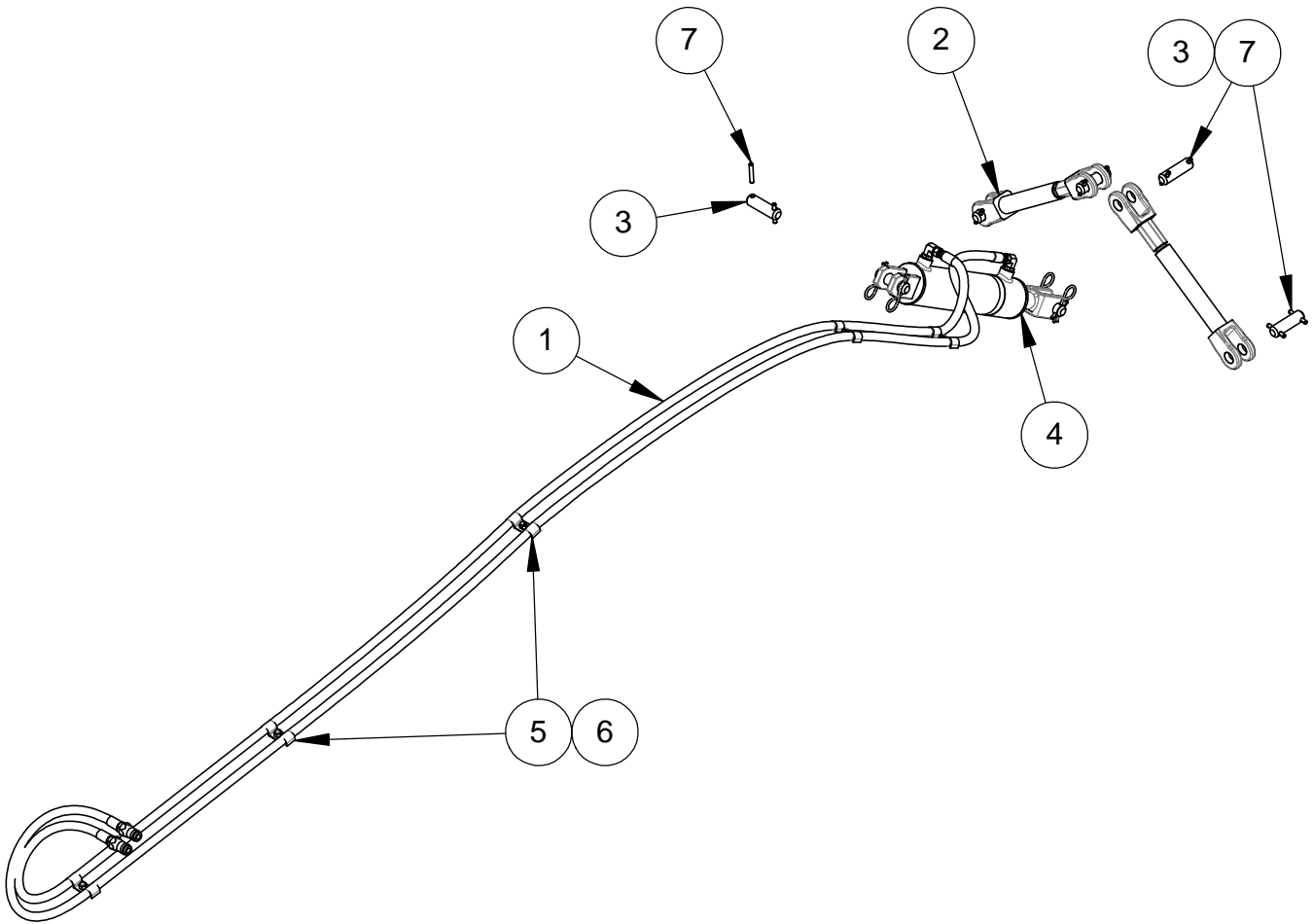



LASER POST KIT (HLL) N-36E04 (OPTION)

Parts

ITEM	NO	DESCRIPTION	QTY
1	N-36009	LASER POST	1
2	N-36010	SWIVEL SUPPORT	1
3	46AB008	HARDENED FLAT WASHER 1/2"	10
4	47AB00813	NYLON LOCK NUT 1/2-13 NC	5
5	45AA008130408	HEX BOLT 1/2-13NC x 4 1/2" GR5	1
6	45AA008130108	HEX BOLT 1/2-13NC X 1 1/2" GR5	4
7	47AE00813	FLANGE NUT 1/2-13NC	2

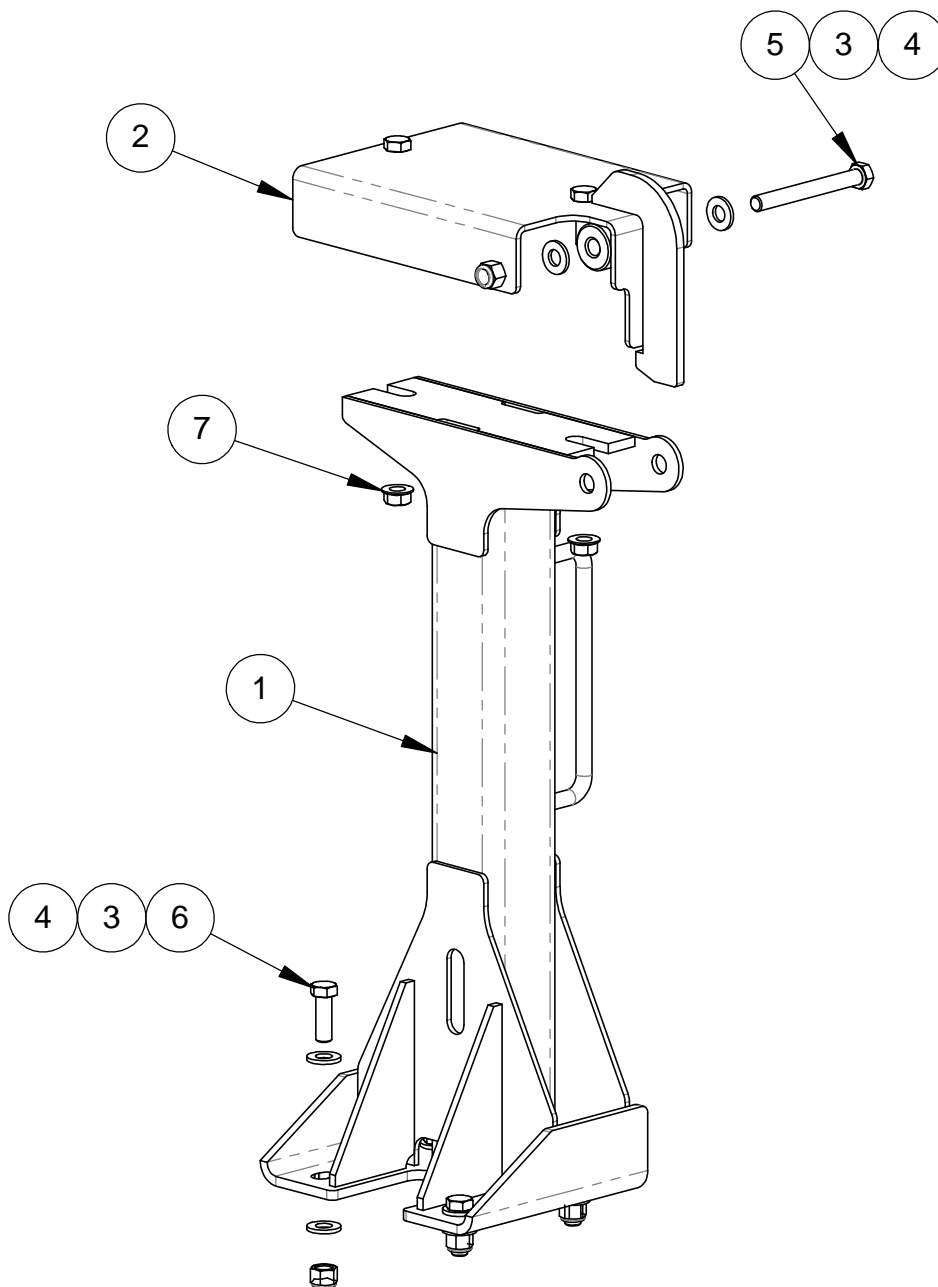



GPS POST KIT (HLL)
N-36E05 (OPTION)

Parts

ITEM	NO	DESCRIPTION	QTY
1	N-36011	GPS POST	1
2	46AB008	HARDENED FLAT WASHER 1/2"	8
3	47AB00813	NYLON LOCK NUT 1/2-13 NC	4
4	45AA008130108	HEX BOLT 1/2-13NC X 1 1/2" GR5	4

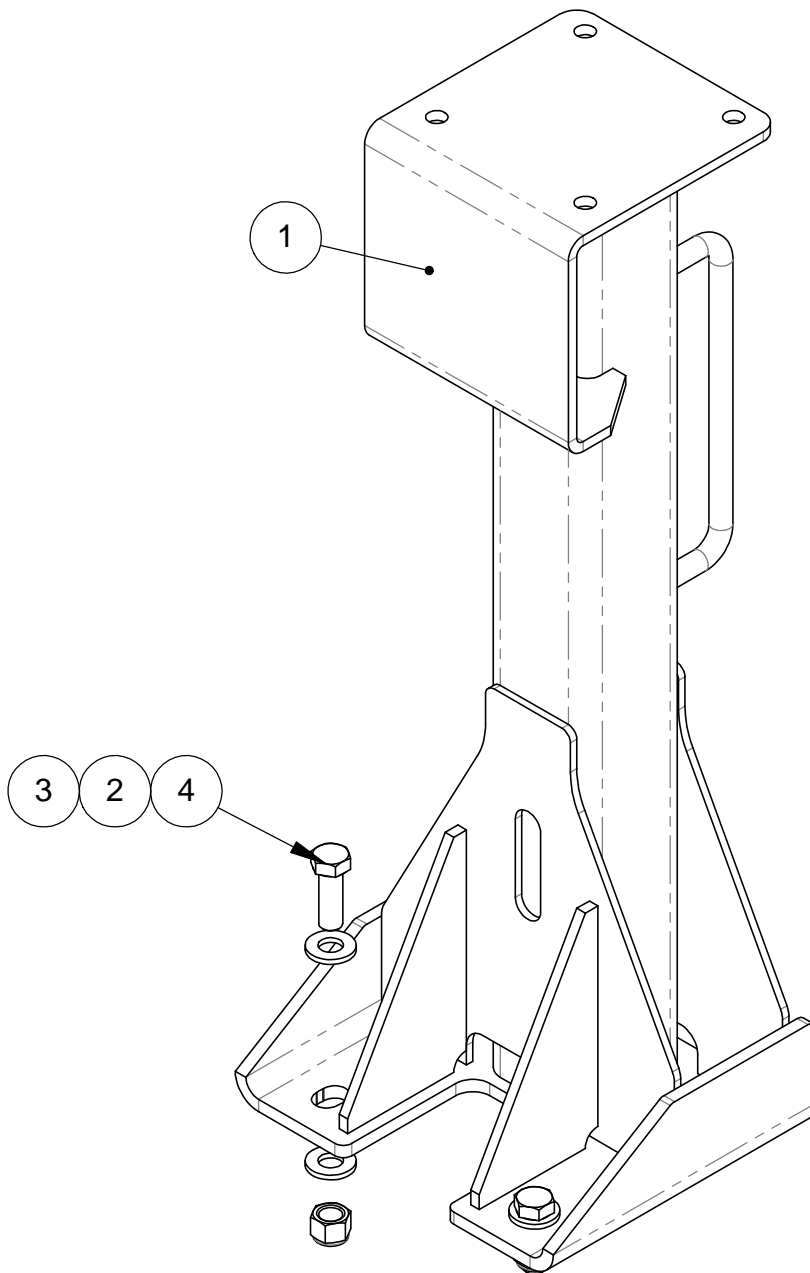



OPTION FEMALE ATTACHEMENT

Parts

FOR PIN 1 1/2"
UN-20072

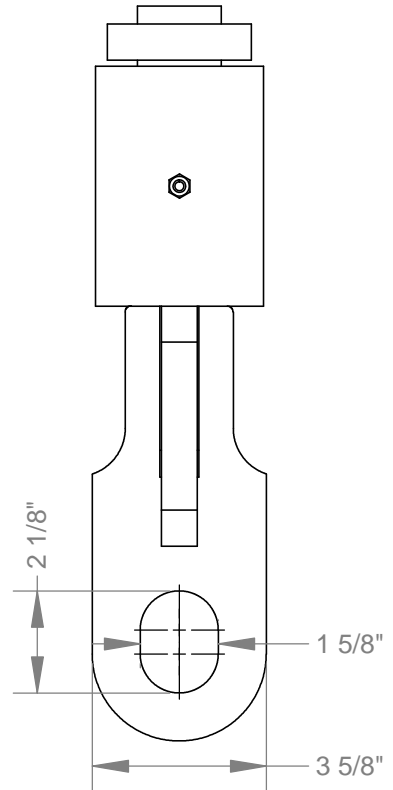
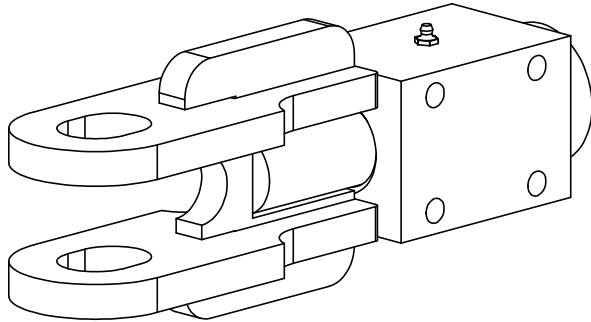

FOR PIN 1 1/4"
UN-20075

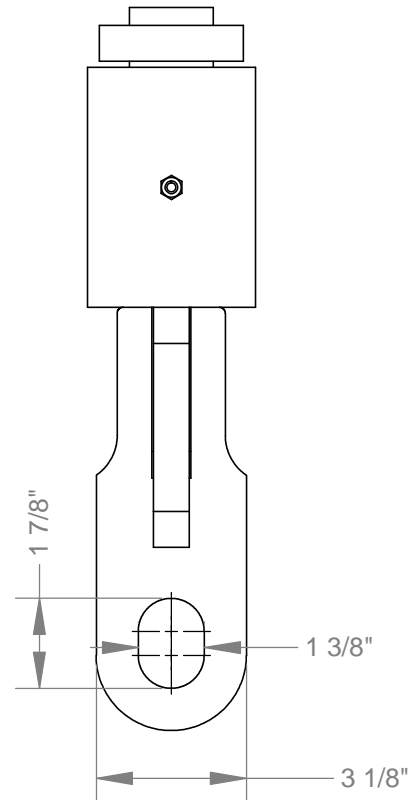
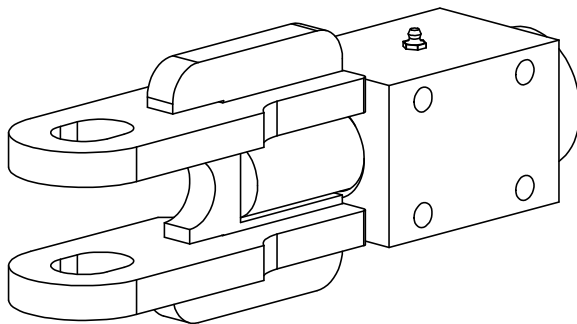



Warranty Policy on new S Houle equipment

S Houle Inc. offers a warranty on all new equipment for a period of **1 year after date of retail purchase**, according to the terms listed below:

1. **AN APPROVAL FROM S HOULE INC. IS REQUIRED BEFORE ANY REPAIRS OR WARRANTY CLAIMS, WITH ACCOMPANYING PHOTOS AND THE EQUIPMENT'S SERIAL NUMBER;**
2. All claims must be received **30 days after date of approval;**
3. The equipment is F.O.B. St-Germain-de-Grantham at all times;
4. All defective parts must be returned to S Houle Inc. or retrieved by a representative of the manufacture **within a period of 30 days following the warranty claim;**
5. The S Houle warranty covers all defects in material or fabrication of the products only, and therefore does not covers the normal wear or non-recommended utilization of the product. All breaks resulting from an accident or abusive use will not be covered by the warranty policy;
6. The warranty does not cover any traveling fees to gain access to the equipment for evaluation or repairs;
7. Only original parts or S Houle approved parts will be considered appropriate for warranty claims;
8. S Houle Inc. reserves the right to refuse any labor time deemed excessive for any repair work claimed on warranty.
9. The labor fees compensated on warranty claims may never exceed **100\$/hour;**
10. On request, S Houle Inc. can provide the service of a road mechanic to effect repairs, for a fee of 100\$/hour + travel fees of 0.60\$/km;
11. The standard color of all equipment out of the factory will be S Houle yellow unless specifically requested by the client;
12. The warranty policy does not apply to the **NORMAL WEAR PARTS** listed below:

Examples: Flow divider, cutting edges, bolts, nuts, spring blades, skid shoes, skid shoe bolts, sliders, chaines and chain hitches, cast iron shoes, hydraulic hoses, clutch and clutch components, gearboxes, driveshafts and others.

PURCHASER'S RESPONSIBILITIES

The present warranty presumes a correct maintenance and periodic inspections of the equipment by the owner, as described in the Owner's Manual provided with the equipment at time of purchase. The cost of regular maintenance or required servicing is the responsibility of the client. The buyer must conserve all receipts proving that the required maintenance has been respected.

EXCLUSIONS ON SUBSEQUENT MANUFACTURER UPGRADES

S Houle Inc. reserves the right to modify, change or improve any product with no obligation to replace or modify any previously purchased equipment.



Fabrication S.Houle inc.

300 Industrial blvd.
St-Germain-de-Grantham, Quebec, Canada, J0C 1K0
Phone : 819 395-4380 Fax : 819 395-5516
Toll free : 1 888-404-4380
E-Mail : info@shoule.com Web: www.shoule.com

Product Registration

Dealer instructions:
Make sure registration is complete and signed.

Product Information :

MACHINE MODEL : _____ DELIVERY DATE : _____ / _____ / _____
mm dd yyyy
SERIAL NUMBER : _____
OPTIONAL EQUIPMENT : _____

Customer Information :

FIRST & LAST NAME : _____ PHONE : _____
MAILING ADDRESS : _____ EMAIL : _____
Civic number and street
City
State / Province Zip Code

Dealer Information :

DEALER NAME : _____ PHONE : _____
MAILING ADDRESS : _____ EMAIL : _____
Civic number and street
City
State / Province Zip Code

Signatures :

Owner or designated representative signature

Authorized dealer signature
Note : Both dealer and owner must sign in order to validate the warranty.

I hereby acknowledge that:

- | | |
|--|--|
| <ol style="list-style-type: none">1. I have received and accepted delivery of equipment described.2. The equipment was checked thoroughly for loose or missing parts and has been adjusted in accordance with the pre-delivery checklist.3. I have been provided with and have carefully read the instruction manual.4. I have read and understand the nature and extent of the warranty and understand clearly that there were and are no other representations or warranties, either express or implied, made by anyone.5. A copy of the present document must be completed and transmitted to Fa- | <ol style="list-style-type: none">6. brication S.Houle as soon as possible, in order to process your warranty.6. I have been advised on proper operation, maintenance and lubrication procedures of this equipment.7. I have been instructed on and do understand the application, limitations and capacities this equipment was designed and recommended for, all as described in the Instruction Manual and other literature published by Fabrication S.Houle inc. |
|--|--|

ONE YEAR WARRANTY COVER PARTS ONLY, EFFECTIVE WHEN THIS FORM HAS ALL APPLICABLE INFORMATION COMPLETED, IS SIGNED BY BOTH THE OWNER AND THE DEALER AT THE TIME OF DELIVERY, THEN FORWARDED TO **FABRICATION S.HOULE INC.** WARRANTY SERVICE MAY BE DENIED IF THIS FORM CONTAINS FALSE INFORMATION OR IS INCOMPLETE.



Fabrication S.Houle inc.

300 boul. Industriel
St-Germain-de-Grantham, Québec, Canada, J0C 1K0
Tél : 819 395-4380 Téléc. : 819 395-5516
Sans frais : 1 888-404-4380
Courriel : info@shoule.com Site : www.shoule.com

Fabrication S.Houle inc.

300 Industrial blvd
St-Germain-de-Grantham, Québec, Canada, J0C 1K0
Phone : 819 395-4380 Fax. : 819 395-5516
Toll free : 1 888-404-4380
E-mail : info@shoule.com Web : www.shoule.com